

## LLYNNVILLE TOWN COUNCIL

February 20, 2018

**PRESENT:** Doris Horn, Stacy Tevault, Eric Erwin, J. William Bruner, Sherry Jones

Doris called the meeting to order at 6:00 PM. She then asked for a moment of silence then asked everybody to join in the pledge of allegiance.

Doris informed everybody there are no minutes to go over this week. She then asked if there were any questions or comments about the bills being paid February 7 through February 20 2018. Eric then stated he had an issue with the Fire Protection Territory for the bill and the amount of \$16\_\_\_ for pants. Either last year or the year before they came before the board and asked for over \$9000 for turnout gear. At that time the board was told they had all the safety gear and requirements they needed to be in compliance. So we need to know if they have more members, if they got a new member and the equipment doesn't fit, if they were damaged or what reason they need new gear. Stacy commented that they need more narrative about why they need new equipment especially when it's such a large amount. She also stated they were supposed to keep their old equipment for the cadets. Stacy also commented that it would be helpful to have a list of all the firefighters. Doris said she would ask Sherry to contact the fire department for an explanation. Eric made a motion to pay the bills from February 7 through February 2018. Stacy second the motion. They all voted aye. Motion Carries.

Seth Yates came to the meeting to introduce himself. He will be running for treasurer of Lynnville. He currently works for Thermal incorporation as a project manager in the maintenance department. He wanted to meet the board and sit in on a meeting. Basically to put a face to the name and to see if anybody had any questions for him.

Doris then called Mr. and Mrs. Schroader to speak. Mr. Schroader came to ask permission to make some additions to his yard barn. He provided the board with pictures of the current yard barn. He would like to extend it eight more feet for storage and a workshop area. The addition would be to the front of the yard barn and inside the property line. Eric needed the motion to approve to add eight for it to the yard barn. Stacy second the motion. They all voted aye. Motion Carries.

Doris calls Mike Ruedlinger to speak. He said he has been called several times due to be excessive rain and flooding we have been having lately. This is why he missed the last meeting. He said they got the banners removed today. They had to remove the steel bands which were all bent besides one. They will all need to be replaced. Need to keep an eye on the water coming through the pipe at the dam at Lynnville Lake. Close to 200 gallons per minute. Doris said she talked to Ray Bunner today, he said he was going to go fix that pipe. Mike and Eric both agreed they don't think Ray has the equipment needed to move all the dirt and fix the pipe but they will have him go look at it anyway. If he can't do it Doris suggested have the Engineers looking at it. Eric also mentioned capping the pipe. Mike agreed and said he had actually thought of that also

Mike wanted to know if they wanted him to clean the old pumps and other equipment that will be replaced. He was thinking after their cleaned on putting them and storage instead of getting rid of

them. We thought it would be a good idea to keep them around just in case. Doris also mentioned we might be able to sell them to another town. Mike talked to the Danny Simon, he thinks it would be a good idea to take the old distribution panel out and put the new panel in the little room they store bleach.

Doris then asked how the water meter readings are coming. Mike said they had half of them done but Gary had to help at the plant. Mike said he would help get the rest of them done. He said there's four days till the end of the month between the two of them they should be able to get them done by the end of the month. Doris also asked him to take the flags up tomorrow. He agreed. Mike said as soon as they were done reading the meters they would start getting the stop signs up. As of right now they have 10 signs raised. Eric made the comment whenever they are reading meters were working on intersections they need to have the strobe lights on and the safety vests on. Eric is going to go pick up the safety vest from Aigner's. Mike said he didn't think the strobe light work so he will probably have to buy a new one.

Doris called Bill Pemberton to speak. Bill wants to get some waste water for his building. He was going to use the existing line but after digging found there was no existing line. Since the line that was supposed to be there wasn't he had to T-off from the other line. The reason he's here is there is a \$1.09 per foot fee to hook up to sewage. He wants to know if the fee could be waived because he is spending extra money putting a line in the supposed to be there but isn't. He's already spent around \$1600 which he showed the board receipts. Mr. Bruner stated he agrees with waiving the fee since on all the plans and maps it says there is a line there. Stacy, Doris and Eric agree since it's stated on the Town's AZBILL the line is but not the fee should be waived. Bill said while he has the trench opened put it in the wastewater line he will also be putting in a water line. Mike told them there are some distance regulations for wastewater and water lines. Mike told him they would get together and go over plan's and maps to play now where the lines will be located. Eric made a motion to waive the no \$1.09 per foot the two hook up wastewater with the agreement on completion of the project he gives the town copies of records where he placed all the lines. Stacy second the motion. All voted aye. Motion Carries.

Doris calls Mr. Bruner to speak. Mr. Bruner said the affidavit on Russ, it's ready to go. He was the default judgment already in place so wants this is signed into ready to go.

Doris calls Stacy to speak. After the gentleman got hurt at the falls last year calls were made to reclamation division, she received a call today from Jay Akes, project manager for the Indiana reclamation division. The message he sent is they are gathering information, and would like to come out next week to get some data about the area. He also sent a permission to survey form to sign and send back.

Stacy then brought up having the town wide yard sale. The yard sale will be the last Saturday in April of every year. This is this you talk to the board to see if there's anything the board could help with getting the yard sale up and going. One of the suggestions she has gotten is to see if it's in the budget to have porta potties available. Stacy is also going to look into having some signs made but instead of having the date put on them, she will have the "last Saturday in April" so the signs can be used from year to year.

Stacy is next item is our Easter egg hunt is the same day as Boonville community Easter egg hunt is the same day. Their Easter egg hunt is 10:00 so hopefully it will affect ours.

Stacy has also gotten several calls about the fire department going the wrong way on runs. This has happened several times so they wanted to reach out to the chief to get some training on roads and directions around Lynnville. She thinks if there might be people on the fire department that are not from Lynnville and don't know the area well. Mike brought up there are many houses in Lynnville with no house numbers. Several of the board members thought there was an ordinance passed several years ago about houses needing to have house numbers displayed when 911 was introduced. Mr. Bruner said he was pretty sure it was a county ordinance. Doris said she would give the chief a call. She also said she would check about ordinances on having numbers on house.

Doris continues the meeting: Pastor Spencer is getting with the other churches about the Easter egg hunt which will be in March 24 at 9:30 AM. The signs are ordered from B hive, 5 for \$100. Since all the churches would like to participate we will be changing the signing to read "Lynnville Community Easter Egg Hunt". The school has also been called in some of the kids are going to be filling the eggs and the grade school will be passing out fliers to each student. Doris also discussed how she would like to separate areas were different age groups.

Doris would also like to know if we could get some money for Missy to get flowers and plants for the pots along Main Street. Stacy said she would like Sherry to review the budget and let the board know how much is available for flowers.

Doris next item is April 21 is community cleanup day. North Friendship Church wants to let the town know they will be going to different sections of the town and then go to Mead Valley to help people clean up that need help. They will have trailers for trash and go help the elderly and disabled or whoever would ask for help. They would like to do this every year on Earth Day. They also want to have a prayer service the first Saturday in May, June and July at the town's gazebo. They would have hot dogs, hamburgers and bottled water for the kids. This is a public area for the community to use.

Doris next item is Donna Goodman's property. This property needs to be cleaned and she has already been sent a letter of termination. Mr. Bruner said he would call Donna's daughter about getting the property cleaned up. Doris also said there is a property near Donna's where the son added myself to the lease but the mother is in a nursing home. She wanted to know if it was necessary to take the mother's name off the lease. Mr. Bruner said that was not necessary.

Doris has also been told by some of the park residents a lady that has been having the parties the police have been called to, has been having loud parties again. Doris was also told the police have been called to her property lately. She has already been warned if she had any more police activity at her house her least maybe terminated. Stacy said they'd need to contact Officer Flowers to check on police activity as soon as possible.

Eric has received numerous phone calls about the blue house on Cherry Street. It has been reported they have an abundance of trash again which is blowing into the street and neighboring properties. Mr. Bruner stated he is already scheduled to go to court over this on March 15. Stacy also brought up when people make complaints they need to be encouraged to make the complaint themselves to show add multiple complaints from multiple people in the record.

Doris spoke to Mr. Bunner today about cleaning out the ditches on Peach Street which would help to drain that water that is just sitting in the ditch. By cleaning out the ditch it will let the water drain out of

town. When Doris went to the planning commission meeting she brought up the house is on highway 68 complaints of water sitting in their yards. They gave her a 1-800 number that goes to Indianapolis but once they get the complaint they check with their divisions to see if they have completed a project and if not they will come out to see what they can do about it. It's been flooding there for 30 to 40 years so it will be great to get that taken care of. When they do get those ditches cleaned out the town will have to put the new culvert there and on Vine Street.

Nobody has anything else Eric made a motion to close the meeting. Stacy second the motion. Everybody voted aye. Motion Carries.

LYNNVILLE TOWN COUNCIL

 \_\_\_\_\_

President

 \_\_\_\_\_

Member

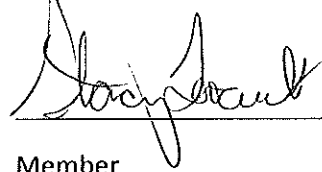
 \_\_\_\_\_

Member

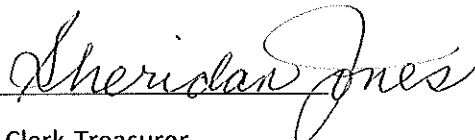
ATTEST:  \_\_\_\_\_  
Clerk-Treasurer

Feb. 20, 2018

- 1 Seth Yates
- 2 Bill Pemberton
- 3 Vibeke & Willie Schroeder
- 4 W. R. [unclear]

# LNB COMMUNITY BANK

To: Lynnville Volunteer Fire Department, Town of Lynnville as a Participating Unit, Hart Township as a Participating Unit, and the Lynnville-Hart Township Fire Protection Territory Advisory Board

From: Bradley K. Pemberton, President & CEO

Date: May 1, 2017

Re: Payment Scenarios on Proposed Fire Truck Loan

Following are payment scenarios based on the terms presented in the proposal dated April 4, 2017. The rate proposed is equal to the 5 Year Treasury at the time of closing plus a margin of 1.25%. As of April 4, 2017, the rate would have been 3.25%.

Loan Amount: \$225,000  
Term: 6 years – semi annual payments  
Rate: 3.25%  
Payment: \$20,788.96

Loan Amount: \$200,000  
Term: 6 years – semi annual payments  
Rate: 3.25%  
Payment: \$18,479.08

Loan Amount: \$175,000  
Term: 6 years – semi annual payments  
Rate: 3.25%  
Payment: \$16,169.19

Loan Amount: \$150,000  
Term: 6 years – semi annual payments  
Rate: 3.25%  
Payment: \$13,859.31

*Bal. 172,593.00 - 100,000.00 down  
prnt made*

Please note that payment calculations are approximate and cannot be exactly calculated until a closing date is determined.

If you have any questions, or need additional information, please let me know.

Lynnville	Chandler	Newburgh	Boonville
P: 812-922-3231	P: 812-925-3326	P: 812-858-1605	P: 812-897-4700
F: 812-922-3233	F: 812-925-2207	F: 812-858-1640	F: 812-897-4725

LYNNVILLE UTILITIES  
ADJUSTMENT FORM

NAME: Rickie Bullington

DATE: 2/28/18

ACCOUNT # 1028009

Water or Wastewater (Circle One)

Reason for Adjustment:

Leak in pipes between  
road and house

Amount of Adjustment requested: 321.75

Amount of Adjustment approved: \_\_\_\_\_

Board Signatures:

Devin Horn  
[Signature]  
[Signature]

321.75  
- 1.62  
-----  
320.13  
23.17  
-----  
296.96

Date approved: 3-6-18

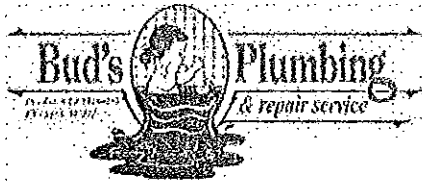

Bud's Plumbing Service Inc.  
 400 E Illinois St  
 Evansville, IN 47711  
 Phone 812-423-5851  
 Fax 812-424-5866

Invoice 14279066  
 Invoice Date 2/14/2018  
 Completed Date 2/14/2018  
 Customer PO

**Billing Address**  
 Rick Bullington  
 3029 Rugby Avenue  
 Evansville, IN 47711 USA

**Job Address**  
 Rick Bullington  
 110 Cherry St.  
 Lynnville, IN 47619 USA

**Description of Work**

Task #	Description	Quantity	Your Price	Your Total
BH-100-480	<b>Backhoe &amp; Operator</b> • 480M • Requires Utility Locate • Requires Excavation waiver • Powers Excavating  Repair water line at water meter, and replace 100' of water service with new 3/4" pex water line. Remove and cap off water line to yard hydrant. There is too much ground water in the ground to work on the water line, so we capped it off, and reduced the price. We can return to install a new yard hydrant under dryer weather conditions.	1.00	\$800.00	\$800.00

Paid On	Type	Memo	Amount
2/14/2018	Check-SCAN (Mobile Scan)		\$800.00
<b>Sub-Total</b>			\$800.00
<b>Tax</b>			\$0.00
<b>Total Due</b>			\$800.00
<b>Payment</b>			\$800.00
<b>Balance Due</b>			\$0.00

\*Estimate-requires 1/3 Deposit Before Scheduling, and Balance Due Upon Completion  
 \*\*Invoice-Due upon Completion

I hereby authorize the work described above and agree to the terms and conditions as stated on this form. I recognize that aged and deteriorated plumbing fixtures, piping, and appurtenances may no longer be serviceable, and I agree to hold Bud's Plumbing Service Inc. blameless for any damages or destruction to those items as a result of these repair efforts. I understand Bud's Plumbing Service Inc. will make 3 attempts or 3 passes through line in an effort to clean this drain. If the drain does not open additional work may be required, and that there may be additional costs involved. I further agree and understand that I am fully responsible for any broken or stuck drain or sewer cables as a result of these conventional drain cleaning efforts. I agree Bud's Plumbing Service Inc. may leave or abandon a broken or stuck sewer cable if I am unable or unwilling to pay for additional work to remove the cable. I agree to pay for all work, goods and services being provided, and I agree to perform the obligations set forth in the applicable cardholder agreement with the credit or debit card user agreement. A service charge of 1.5% per month (18% per annum) will be charged on all balances 10 days or more past due.

2/14/2018  
 I hereby acknowledge the satisfactory completion of the above described work.

I hereby acknowledge, by presenting a check as an instrument for a payment, I have the authority and I am authorizing MLC Plumbing Service, dba Bud's Plumbing Service Inc., to electronically debit the checking account for the amount of said check and on the day of receipt of said check.

I hereby acknowledge, by presenting a credit card or credit card information for a payment, I have the authority and I am authorizing MLC Plumbing Service, dba Bud's Plumbing Service Inc., to electronically debit the payment to the said credit card account on the day of receipt of said credit card account information.

- CONDITIONAL WARRANTIES**
- \* 6-year tank and 1-year parts and labor warranty on new water heaters.
  - \* 1-year parts and labor warranty on new pumps, faucet/fixture installation, repipe/sewer/drain installation.
  - \* 30-day parts and labor warranty on repair of faucet/fixture, and residential drain cleaning.
  - \* NO WARRANTY ON OWNER SUPPLIED MATERIALS.
  - \* NO WARRANTY ON EXISTING PIPE, VALVES, FITTINGS, ETC..
  - \* WE UNDERSTAND YARD REPAIRS ARE NOT INCLUDED.

*Paid Thank You!*

**TOWN OF LYNNVILLE UTILITIES**

P.O. BOX 99  
LYNNVILLE, INDIANA 47619

Service Location		
110 cherry st		
Customer Number		Billing Date
10280 09		12/29/17
Previous Reading	Current Reading	Consumption
From 11/22/17	To 12/22/17	30 Days
1044600	1052500	7900
Service	Tax	Charge
WATER	4.89	69.92
WASTEWATER		102.69
PREVIOUS CREDIT		-6.31
Due Date	Amount Due After Due Date	Amount Due Before Due Date
01/10/18	\$183.14	\$171.19

*Pd. ck # 2420*

*1-10-18*

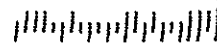

LYNNVILLE UTILITIES  
ADJUSTMENT FORM

812 453-0617

NAME: Karen Barnette

DATE: 2/5/18

ACCOUNT # 1149009

Water or Wastewater (Circle One)

Reason for Adjustment:

Toilet running  
father repaired toilet  
it didn't cost her anything

Amount of Adjustment requested: - 34.06

Amount of Adjustment approved: \_\_\_\_\_

Board Signatures:

Doris Hearn  
[Signature]  
[Signature]

Date approved: 3-16-18 3-6-18

918 <sup>51</sup> 300	
913800	
<hr/>	
2500	
113.33	66.85
-34.06	32.09 Avg
<hr/>	
79.27	34.66
	Karen Barnette

Dear Park Board,

2-1-18

I am currently in the W.C.T. I had plans that my son was to pay bills & take care of my home until my release.

Things did not go as planned. He left by not paying anything. He actually stole my belongings & ran out on me.

I worked very hard on that property as you should know and the thought of losing it for no insurance is scaring me. I love that place & I want to live out my days there.

I am trying to get someone to insure it for me while I'm here. I am still trying.

I will be able to pay lot rent this yr. with my tax return. I do not get alot back but you can have it all if you just let me renew my lease.

I am a single woman & built that house small enough for me to retire in. Please find it in your hearts



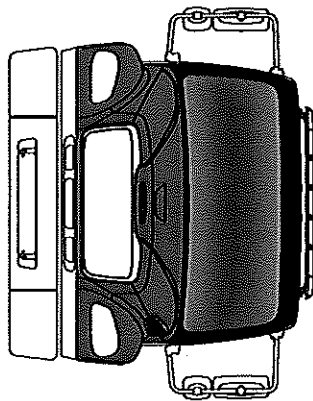
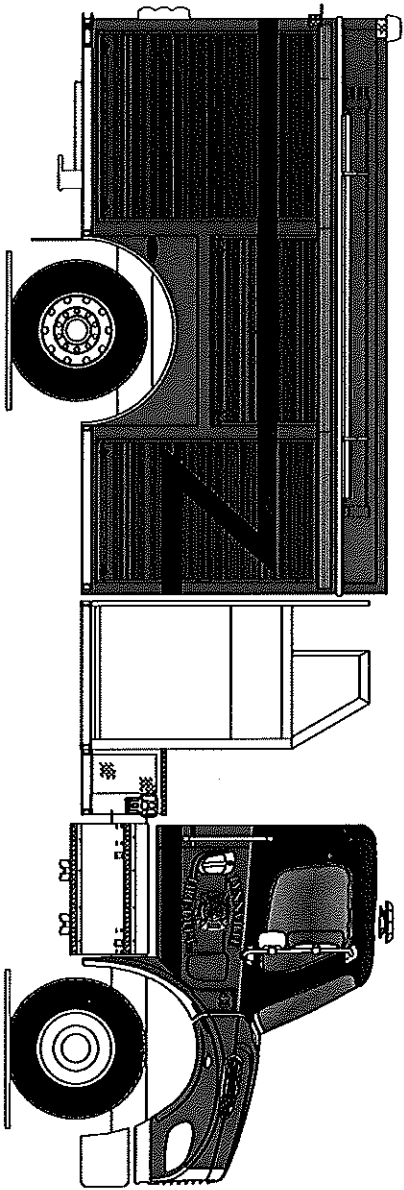

\*\*\*NOTICE OF PUBLIC HEARING\*\*\*

DATE: 1-31-18

DOCKET NO: BZA-V-18-02

APPLICANT: DAVID Goldenberg OWNER: DAVID Goldenberg

ADDRESS: 317 OAK ST ADDRESS: \_\_\_\_\_

Lynnville IN 47619 \_\_\_\_\_

RE: Nature of Case Applicant requests a variance from the requirements as set forth in the Comprehensive Zoning Ordinance in effect for Warrick County, IN to allow ~~an improvement location~~ Permit to be issued for:

An unattached accessory building to be converted into a SFD (Single Family Dwelling) not meeting side yard requirements in a R-1A (Residential one family dwelling)

Dear: Adjacent property owner;

This letter will serve notice to you of scheduled hearing/s of a petition for BZA-V- which has been filed with the Warrick County Area Board of Zoning Appeals.

PREMISES AFFECTED: Property located on the W side of Vine St.

approximately 0 feet ~~meters~~ NW of the intersection formed by Vine St.

and SR 68 Lynnville Town ~~Ship~~, Lot No. \_\_\_\_\_ in

\_\_\_\_\_ Subdivision (if applicable).

BOARD OF ZONING APPEALS hearing to be held in the Commissioners Meeting Room, Third Floor, Courthouse, Boonville, Indiana. Hearing to be held at 6:00pm on Monday, February 26th, 2018 (2/26/18).

Sincerely,

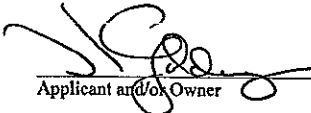
  
Applicant and/or Owner

If you have any questions, please contact the Warrick County Area Plan Office at (812) 897-6190. Written objections to the proposals that are filed in the office of the Warrick County Area Plan Commission before the hearing will be considered. They may be mailed to the Warrick County Area Plan Commission, Historic Courthouse - Room 201, Boonville, Indiana, 47601, or emailed to [apc@warrickcounty.gov](mailto:apc@warrickcounty.gov).

FILED

JAN 31 2018

WARRICK COUNTY  
AREA PLAN COMMISSION